

NRS GATE VALVE, METAL SEATED

Size DN50-DN300 PN16/ANSI 125

Fig. 3129

Specification

- Valves comply with EN1171-2002 , BS3464.
- Metal seat.
- Inside screw.
- Adjustable stem seal.
- Available with handwheel or gearbox (bevel or spur gearbox).
- Flanges to EN1092-2 PN10 or PN16, ANSI B16.1 Class125 (Other types available on request).
- Face to face length in accordance with BS3464.

Working Pressure

- 16bar

Working Temperature

- -10°C to 120 °C

Corrosion Protection

- Internally and externally liquid epoxy painted.

Notes:

- Seats are available integrally machined in body and wedge.
- Design and material are subject to change without notice.



WEFLO

Material Specification and Dimensions

Material Specification

Part Name	Material	EN Spec.	ASTM Spec.
Body	Cast Iron	EN-JL1040	ASTM A126 Class B
Body Trim	Bronze	EN1982 CC491K	ASTM B62 C83600
	CI Integral	EN-JL1040	ASTM A126 Class B
Wedge Trim	Bronze	EN1982 CC491K	ASTM B62 C83600
	CI Integral	EN-JL1040	ASTM A126 Class B
Wedge	Cast Iron	EN-JL1040	ASTM A126 Class B
Wedge Nut	Bronze	EN1982 CC491K	ASTM B62 C83600
Stem	Carbon Steel	BS970 050A20	AISI 1020
	Stainless Steel	BS970 420S37	AISI 420
Bonnet	Cast Iron	EN-JL1040	ASTM A126 Class B
Gasket	Graphite	Non-asbestos	Non-asbestos
Stuffing Box	Cast Iron	EN-JL1040	ASTM A126 Class B
Packing	Graphite	Non-asbestos	Non-asbestos
Handwheel	Cast Iron	EN-JL1040	ASTM A126 Class B

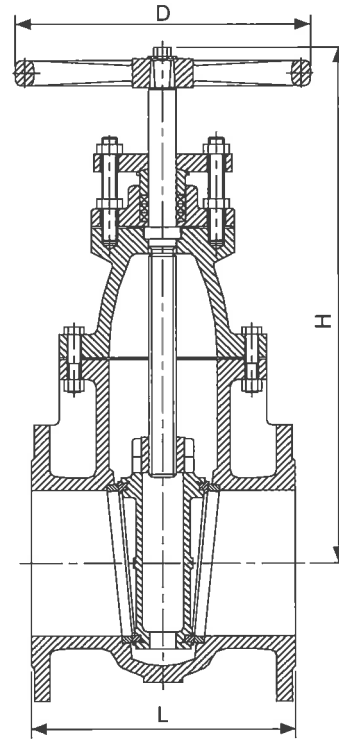

Dimensions (mm)

Size	DN50	DN65	DN80	DN100	DN125	DN150	DN200	DN250	DN300
L	146	159	165	171	191	210	241	273	305
H	306	325	350	405	487	531	650	773	850
D	190	190	190	250	305	305	356	405	457
Weight (kg)	17.0	20.0	24.0	38.0	48.0	68.0	120.0	198.0	295.0

WEFLO VALVE COMPANY LTD.

145-157 ST JOHN STREET, LONDON, EC1V 4PY UNITED KINGDOM

Tel: +44(0) 207 256 7777

E-mail: info@weflovalve.com Web: www.weflovalve.com