

OS&Y GATE VALVE, METAL SEATED

Size DN50-DN600 PN16/ANSI 125

Fig. 3113 – Brass Stem, Fig. 3114 – Stainless Steel Stem

Specification

- Valves comply with EN1171-2002 , MSS SP-70.
- Metal seat.
- Outside stem screw.
- Adjustable stem seal.
- Packing replaceable under pressure.
- Available with handwheel or gearbox (bevel or spur gearbox).
- Flanges to EN1092-2 PN10 or PN16, ANSI B16.1 Class125 (Other types available on request).
- Face to face length in accordance with EN558-1 basic series 3 and ASME B16.10-2000.

Working Pressure

- 16bar for EN1171 valves
- 200psi for MSS SP-70 valve size 2" to 12"
- 150psi for MSS SP-70 valve size 14" and above

Working Temperature

- -10°C to 120 °C

Corrosion Protection

- Internally and externally liquid epoxy painted.

Notes:

- Valve size DN50 to DN300 (2" to 12") available PN25 or Class250 with ductile Iron body and flanges to EN1092-2 PN25 or ANSI B16.2 Class250.
- Design and material are subject to change without notice.



WEFLO

Material Specification and Dimensions

Material Specification

Part Name	Material	EN Spec.	ASTM Spec.
Body	Cast Iron	EN-JL1040	ASTM A126 Class B
Body Trim	Bronze	EN1982 CC491K	ASTM B62 C83600
Wedge Trim	Bronze	EN1982 CC491K	ASTM B62 C83600
Wedge	Cast Iron	EN-JL1040	ASTM A126 Class B
Yoke Nut	Bronze	EN1982 CC491K	ASTM B62 C83600
Stem	Brass	CuZn39Pb3	ASTM B16 C36000
	Stainless Steel	BS970 420S37	AISI 420
Bonnet	Cast Iron	EN-JL1040	ASTM A126 Class B
Gasket	Graphite	Non-asbestos	Non-asbestos
Yoke	Cast Iron	EN-JL1040	ASTM A126 Class B
Packing	Graphite	Non-asbestos	Non-asbestos
Handwheel	Cast Iron	EN-JL1040	ASTM A126 Class B

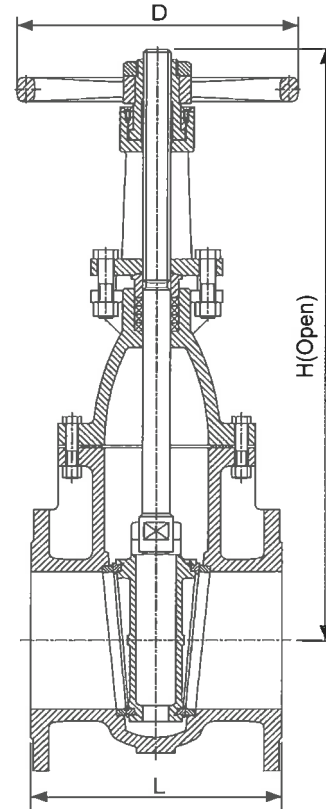

Dimensions (mm)

Size	DN50	DN65	DN80	DN100	DN125	DN150	DN200	DN250	DN300
L	178	191	203	229	254	267	292	330	356
H (Open)	405	415	486	632	710	842	1100	1228	1373
D	190	190	190	250	305	305	356	405	457
Weight (kg)	22.0	24.1	29.5	53.2	70.0	95.8	160.4	251.0	365.0

Size	DN350	DN400	DN450	DN500	DN600
L	381	406	432	457	508
H (Open)	1595	1900	2210	2600	3040
D	508	558	610	610	762
Weight (kg)	450.0	696.0	950.0	1089.0	1520.0

WEFLO VALVE COMPANY LTD.

145-157 ST JOHN STREET, LONDON, EC1V 4PY UNITED KINGDOM

Tel: +44(0) 207 256 7777

E-mail: info@weflovalve.com

Web: www.weflovalve.com