

Materials comply with the requirements of NACE MR 01 75 (2002)

A Notice:  
Bearing for 14" & Larger

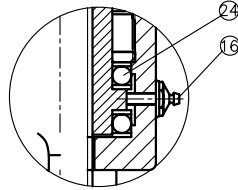

B Notice:  
Yoke for 12" & Larger

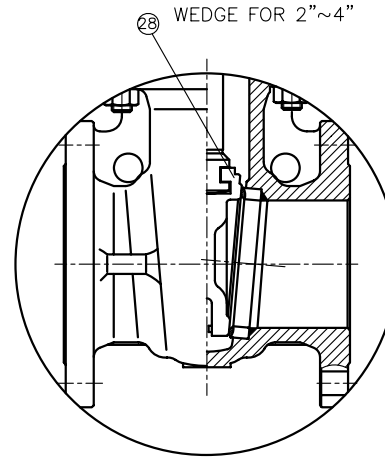
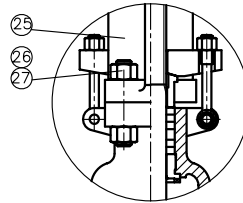

ITEM	NAME	STANDARD MATERIAL SPECIFICATIONS		
		API TRIM 8	API TRIM 5	API TRIM 16
1	BODY	ASTM A216 WCB	ASTM A216 WCB	ASTM A352 LCC
2	SEAT	ASTM A105+STL.6	ASTM A105+STL.6	ASTM A350 LF2+STL.6
3	WEDGE	ASTM A216 WCB+ER410	ASTM A216 WCB+STL.6	ASTM A352 LCC+STL.6
4	STEM	ASTM A182 F6a	ASTM A182 F6a	ASTM A182 F316
5	GASKET	F304+FLEXIBLE GRAPHITE	F304+FLEXIBLE GRAPHITE	F316+FLEXIBLE GRAPHITE
6	BONNET	ASTM A216 WCB	ASTM A216 WCB	ASTM A352 LCC
7	BACK SEAT	ASTM A276 410	ASTM A276 410	ASTM A276 316
8	GLAND PACKING	F304+GRAPHITE	F304+GRAPHITE	F316+GRAPHITE
9	GLAND PACKING	FLEXIBLE GRAPHITE	FLEXIBLE GRAPHITE	FLEXIBLE GRAPHITE
10	GLAND	ASTM A276 410	ASTM A276 410	ASTM A276 316
11	GLAND FLANGE	ASTM A216 WCB	ASTM A216 WCB	ASTM A352 LCC
12	STEM NUT	ASTM A439-D2	ASTM A439-D2	ASTM A439-D2
13	GLAND NUT	Carbon Steel	Carbon Steel	Carbon Steel
14	HANDWHEEL	Ductile Iron	Ductile Iron	Ductile Iron
15	LOCK NUT	Carbon Steel	Carbon Steel	Carbon Steel
16	Grease Nipple	Carbon Steel	Carbon Steel	Carbon Steel
17	EYE BOLT	ASTM A193-B7M	ASTM A193-B7M	ASTM A320-L7M
18	EYE NUT	ASTM A194-2HM	ASTM A194-2HM	ASTM A194-4M
19	PIN	Carbon Steel	Carbon Steel	Carbon Steel
20	BOLT	ASTM A193-B7M	ASTM A193-B7M	ASTM A320-L7M
21	NUT	ASTM A194-2HM	ASTM A194-2HM	ASTM A194-4M
22	NAME PLATE	AISI 304	AISI 304	AISI 304
23	RIVET	AISI 304	AISI 304	AISI 304
24	BEARING			
25	YOKE	ASTM A216 WCB	ASTM A216 WCB	ASTM A352 LCC
26	YOKE STUD	ASTM A193 B7M	ASTM A193 B7M	ASTM A320 L7M
27	YOKE NUT	ASTM A194 2HM	ASTM A194 2HM	ASTM A194 4M
28	WEDGE	ASTM A217 CA15		

PRESSURE-TEMPERATURE RATING ACCORDING TO ASME B16.34

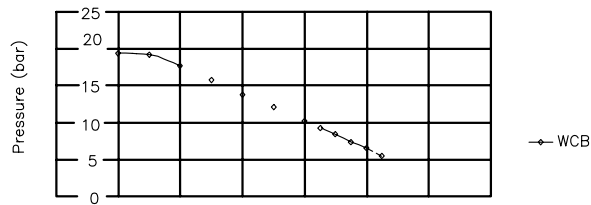

→ WCB

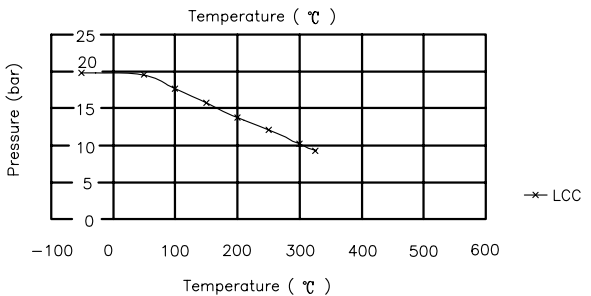

→ LCC

SUITABLE TEMP(°C)	WCB	LCC
ASME B16.34	-29to+425Deg C	-46to+345 Deg C
EU-PED	-5to+425Deg C	-46to+345Deg C
	WATER,STEAM,OIL	

TEST PRESSURE TO API 598 & ASME B16.34		
TEMPERATURE ( 0~38℃ )	WCB	LCC
SHELL TEST (Bar)	29.4	29.7
BACK SHELL TEST(Bar)	21.6	21.8
SEAL TEST (Bar)	21.6	21.8

PROJECT:	----		
CLIENT:	----		
T.T. REF:	----		
ITEM:	----		
REV.	DATE	DRAWN	CHECKED
	9-29-2015	WB	JT

TT Valves UK Ltd

TRACED	DATE	NAME	GATE VALVE CLASS-150
CHECKED			
	SCALE	DRAWING No :	REV:
	---		0

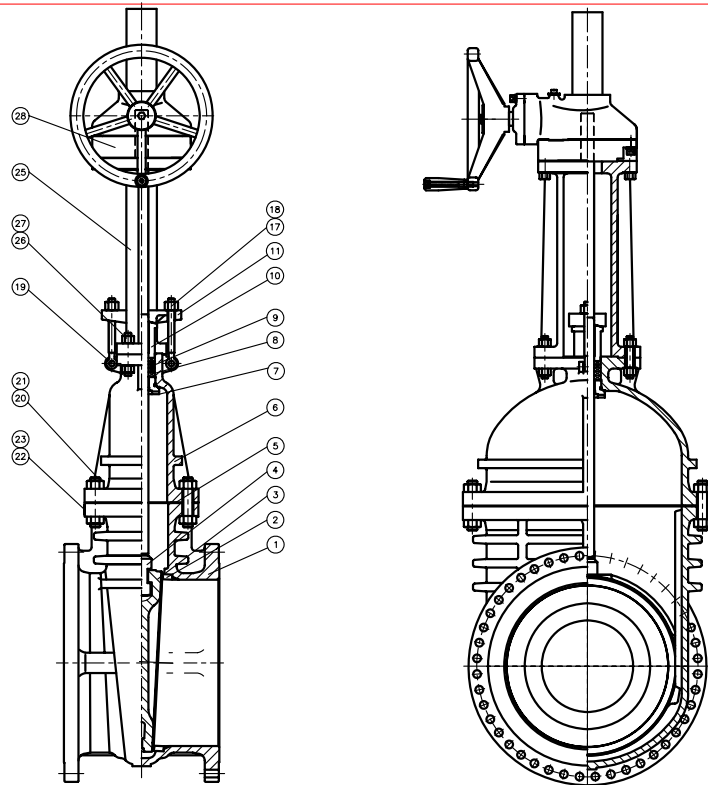

Materials comply with the requirements of NACE MR 01 75 (2002)

ITEM	NAME	STANDARD MATERIAL SPECIFICATIONS		
		API TRIM 8	API TRIM 5	API TRIM 16
1	BODY	ASTM A216 WCB	ASTM A216 WCB	ASTM A352 LCC
2	SEAT	ASTM A105+STL.6	ASTM A105+STL.6	ASTM A350 LF2+STL.6
3	WEDGE	ASTM A216 WCB+ER410	ASTM A216 WCB+STL.6	ASTM A352 LCC+STL.6
4	STEM	ASTM A182 F6a	ASTM A182 F6a	ASTM A182 F316
5	GASKET	F304+FLEXIBLE GRAPHITE	F304+FLEXIBLE GRAPHITE	F316+FLEXIBLE GRAPHITE
6	BONNET	ASTM A216 WCB	ASTM A216 WCB	ASTM A352 LCC
7	BACK SEAT	ASTM A276 410	ASTM A276 410	ASTM A276 316
8	GLAND PACKING	F304+GRAPHITE	F304+GRAPHITE	F316+GRAPHITE
9	GLAND PACKING	FLEXIBLE GRAPHITE	FLEXIBLE GRAPHITE	FLEXIBLE GRAPHITE
10	GLAND	ASTM A276 410	ASTM A276 410	ASTM A276 316
11	GLAND FLANGE	ASTM A216 WCB	ASTM A216 WCB	ASTM A352 LCC
17	EYE BOLT	ASTM A193-B7M	ASTM A193-B7M	ASTM A320-L7M
18	EYE NUT	ASTM A194-2HM	ASTM A194-2HM	ASTM A194-4M
19	PIN	Carbon Steel	Carbon Steel	Carbon Steel
20	BOLT	ASTM A193-B7M	ASTM A193-B7M	ASTM A320-L7M
21	NUT	ASTM A194-2HM	ASTM A194-2HM	ASTM A194-4M
22	NAME PLATE	AISI 304	AISI 304	AISI 304
23	RIVET	AISI 304	AISI 304	AISI 304
25	YOKE	ASTM A216 WCB	ASTM A216 WCB	ASTM A352 LCC
26	YOKE STUD	ASTM A193 B7M	ASTM A193 B7M	ASTM A320 L7M
27	YOKE NUT	ASTM A194 2HM	ASTM A194 2HM	ASTM A194 4M
28	GEAR	COMMERCIAL		

PRESSURE-TEMPERATURE RATING ACCORDING TO ASME B16.34

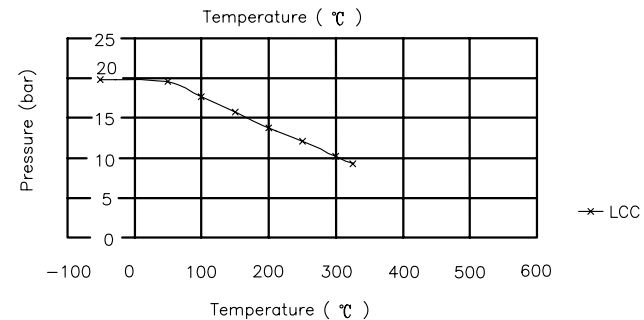
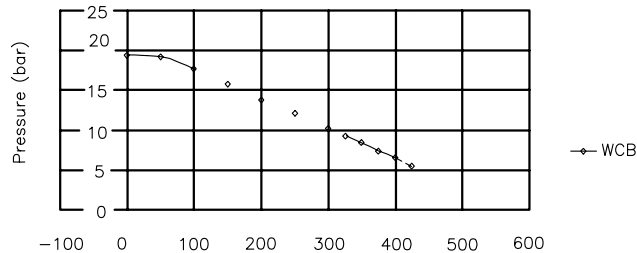

SUITABLE TEMP(°C)	WCB	LCC
ASME B16.34	-29to+425Deg C	-46to+345 Deg C
EU-PED	-5to+425Deg C	-46to+345Deg C
	WATER,STEAM,OIL	

TEST PRESSURE TO API 598 & ASME B16.34

TEMPERATURE ( 0~38°C )	WCB	LCC
SHELL TEST (Bar)	29.4	29.7
BACK SHELL TEST(Bar)	21.6	21.8
SEAL TEST (Bar)	21.6	21.8

PROJECT:	----		
CLIENT:	----		
T.T. REF:	----		
ITEM:	----		
REV.	DATE	DRAWN	CHECKED
	9-29-2015	WB	JT

TT Valves UK Ltd

TRACED CHECKED	DATE	NAME	GATE VALVE CLASS-150
	SCALE	DRAWING No :	REV: 0
	---		

